



 Die Montage darf nur durch entsprechendes Fachpersonal erfolgen.

 → Die Montageanleitung ist nach dem Aufbau an den Marktleiter zu übergeben!

 Aufgestellte Regale dürfen nicht verschoben werden.

Diese Aufbauanleitung gibt Hinweise zur Montage, darüber hinaus sind alle relevanten Vorsichtsmaßnahmen, Vorschriften und Regeln der Technik, insbesondere die der DIN 4844-2, zu beachten. Beschädigte Teile müssen ersetzt werden.

 The assembly has to be done by adequately qualified personnel, only.

 → After the installation, the assembly instructions have to be handed over to the Store Manager.

 Shelves, which have been set up, must not be moved.

These assembly instructions give advice according to the installation, further more all relevant safety precautions as well as rules and regulations of technology, especially DIN 4844-2, have to be observed. Damaged parts have to be replaced.

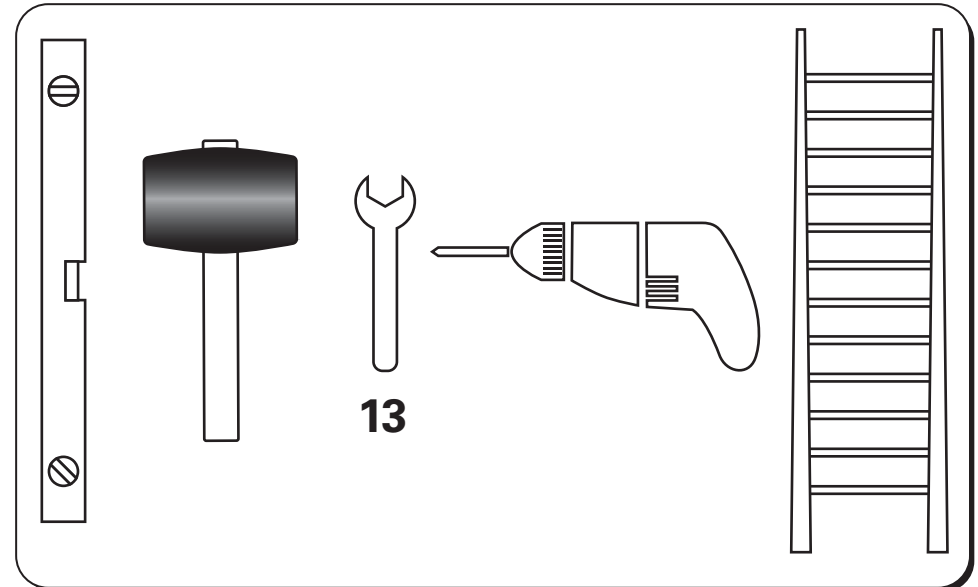
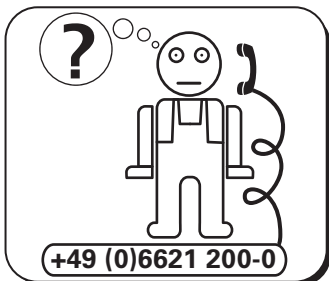
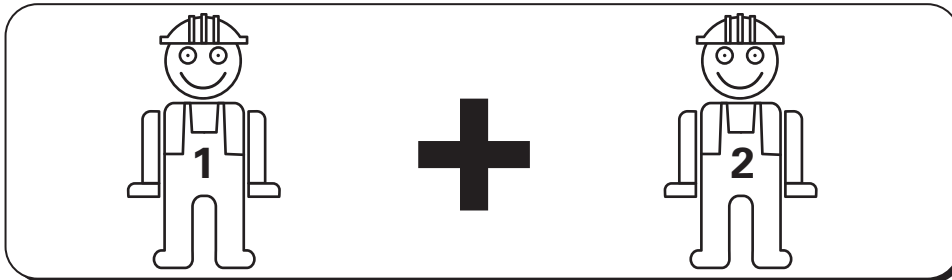

13

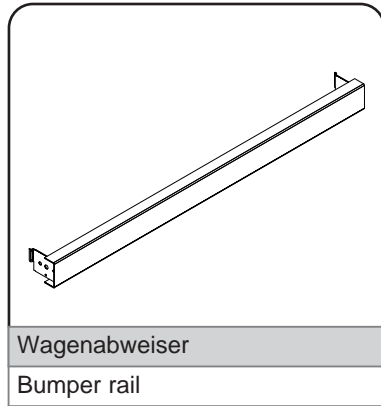
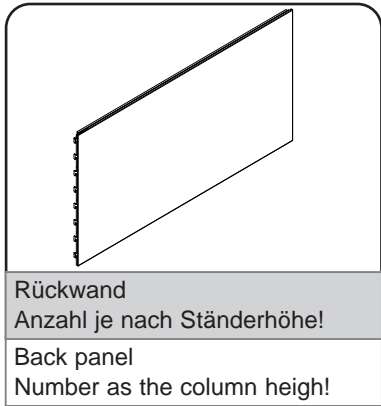
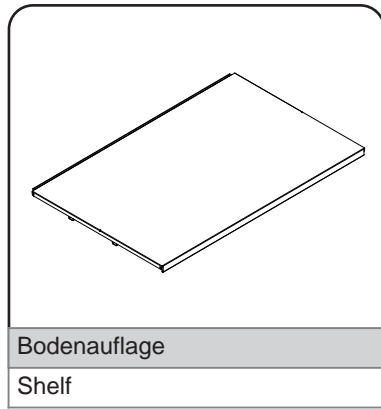
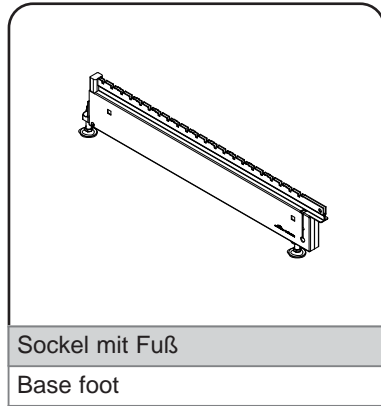
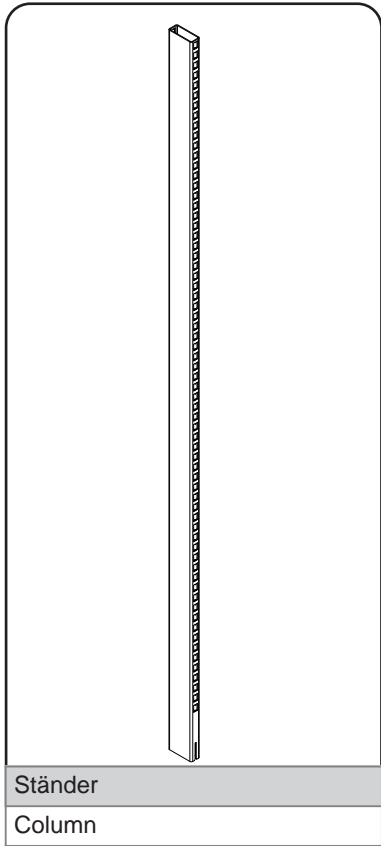

Optional einsetzbar
Optional applicable

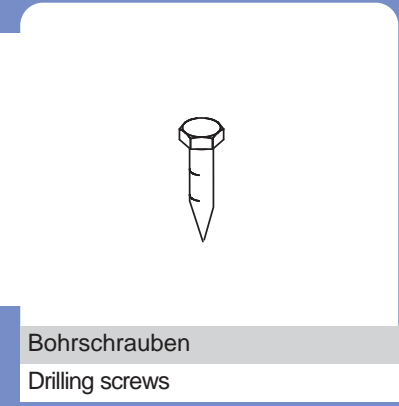
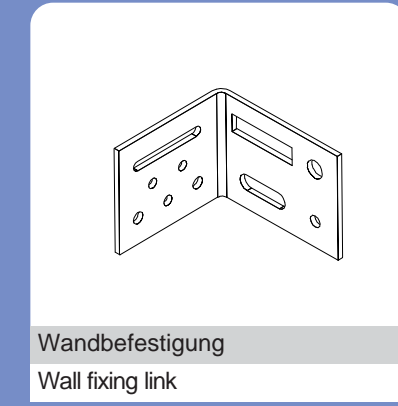
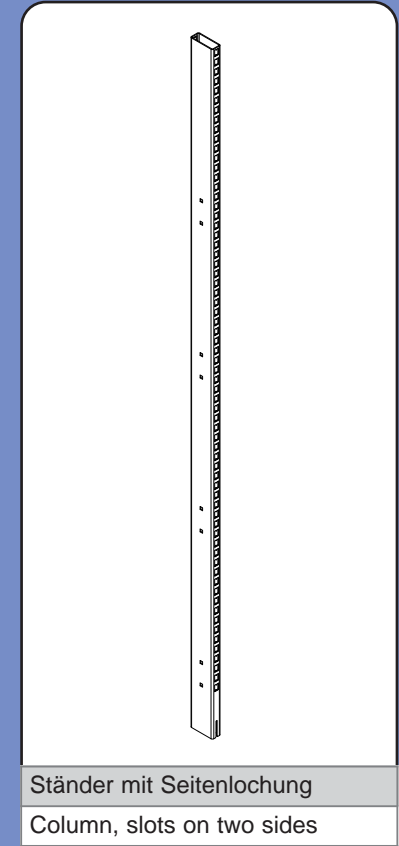
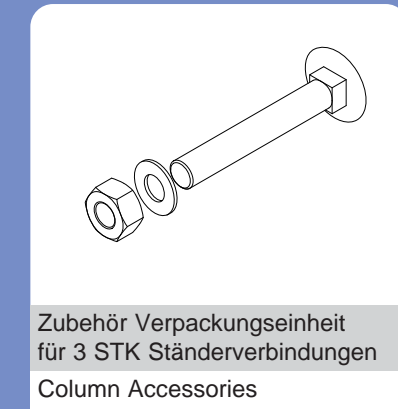
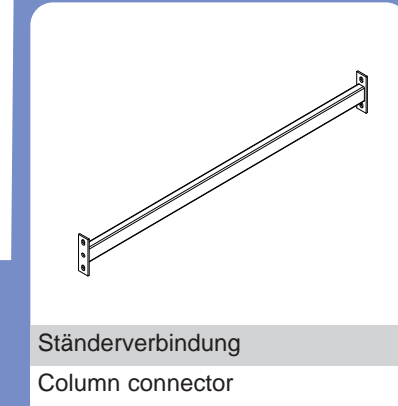
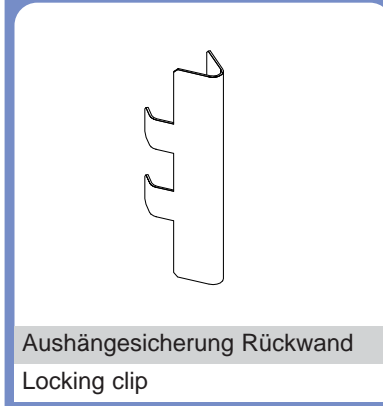
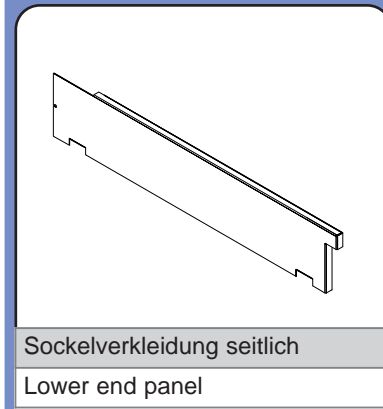

Werkzeuge / Tools

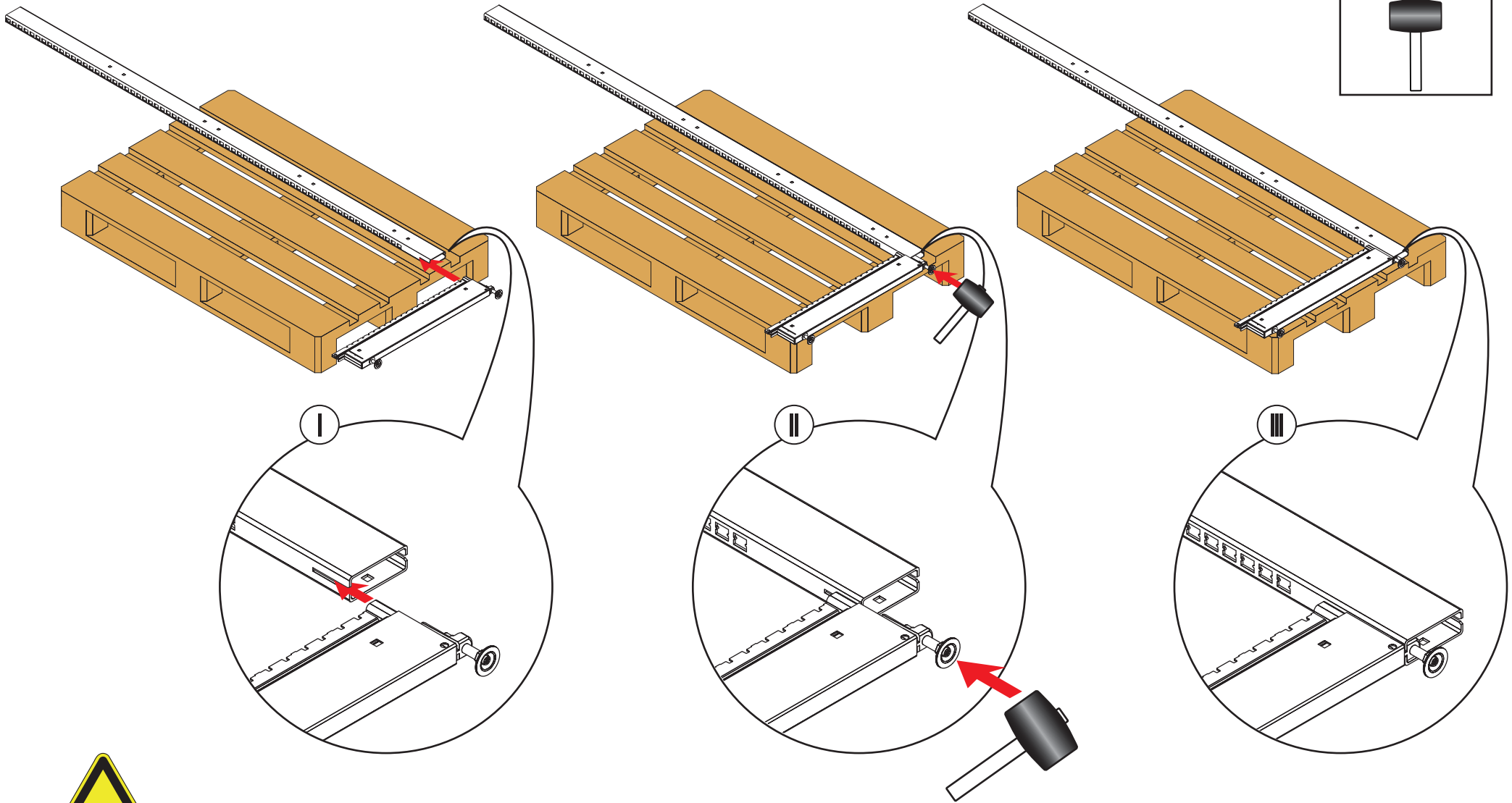
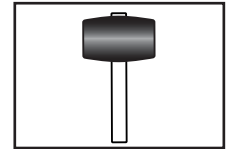

Optional einsetzbar
Optional additionally

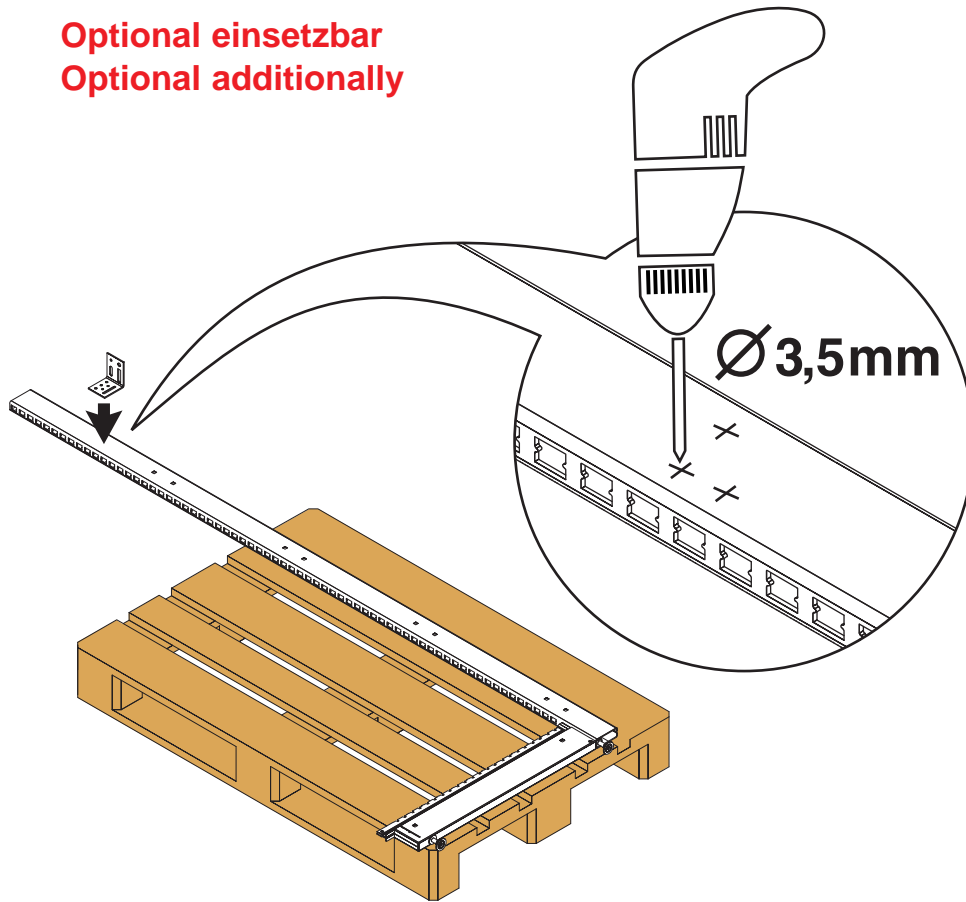

Bohrschrauben nach DIN 7981
Drilling screws / DIN 7981

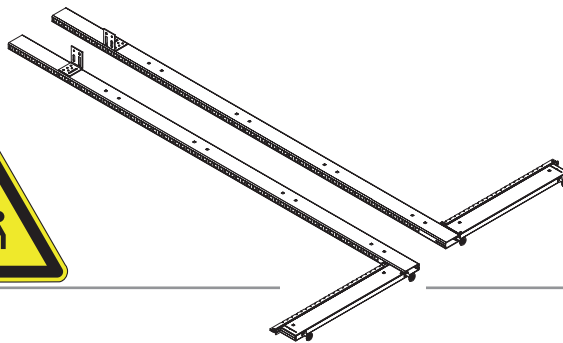
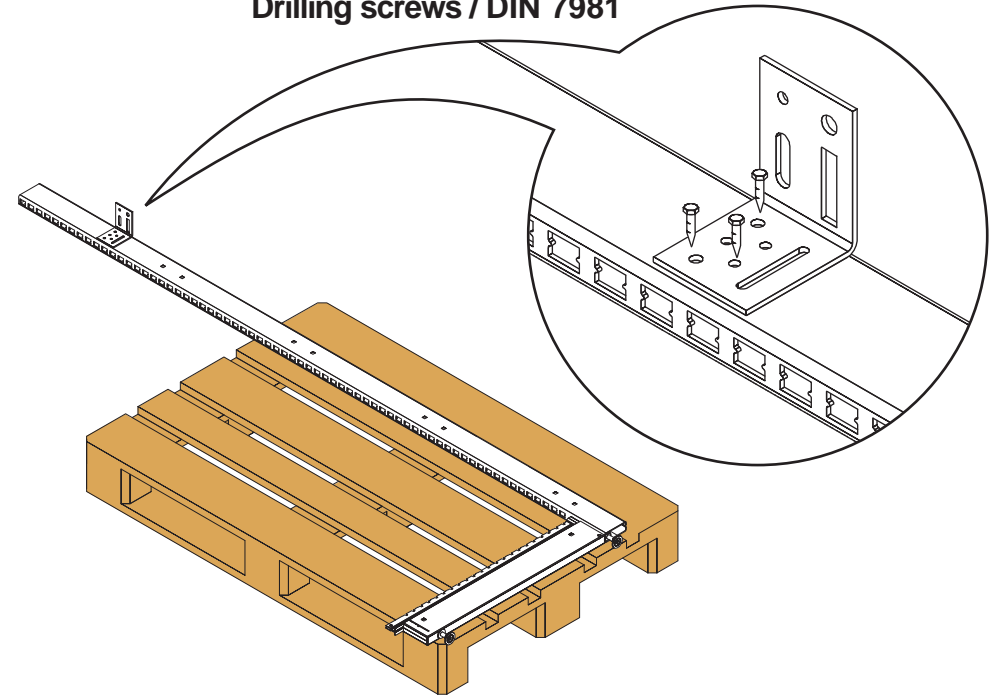
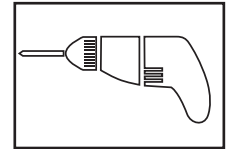

Optional einsetzbar
Optional additionally

Werkzeuge / Tools

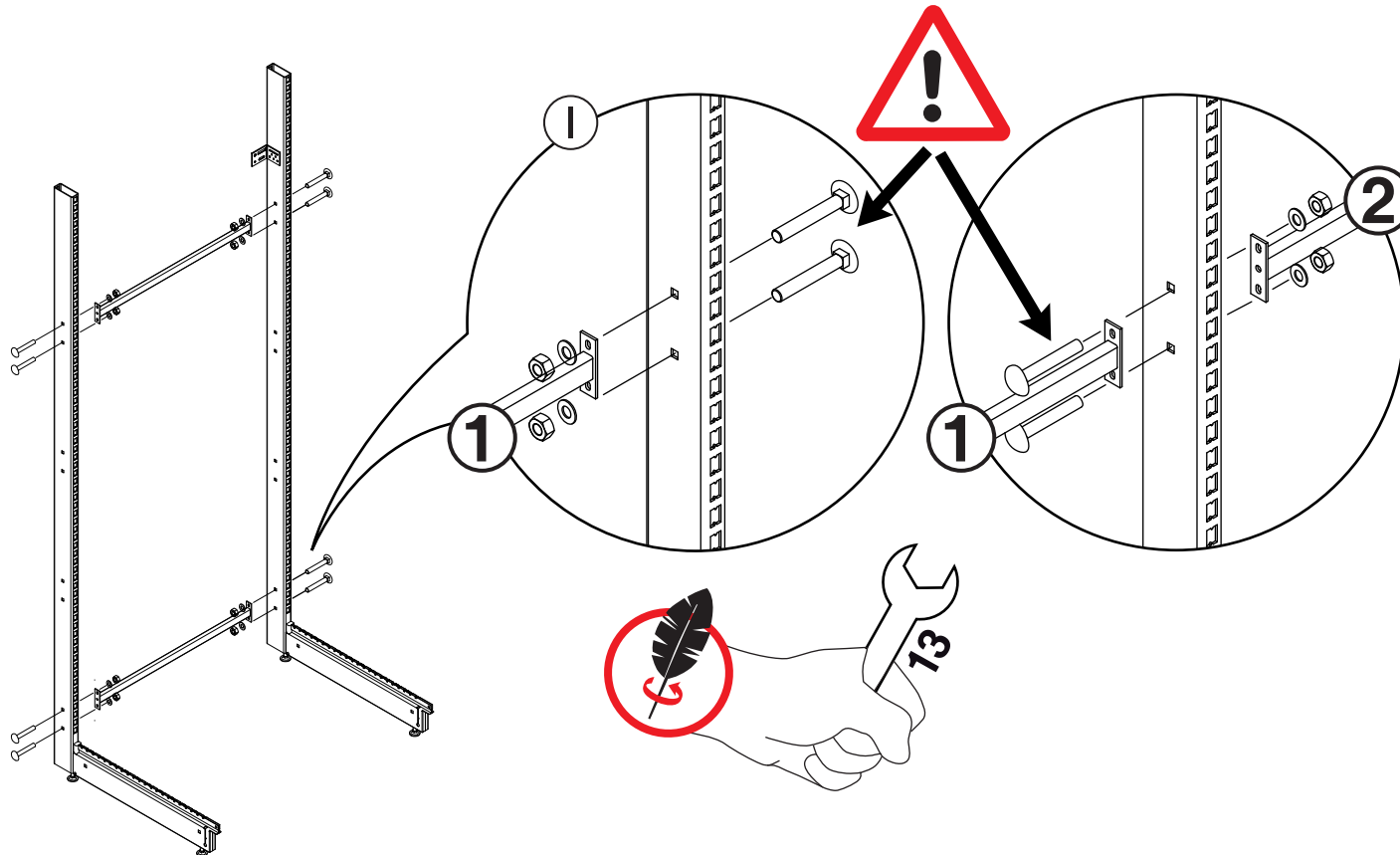
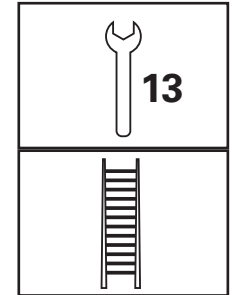

Werkzeuge / Tools

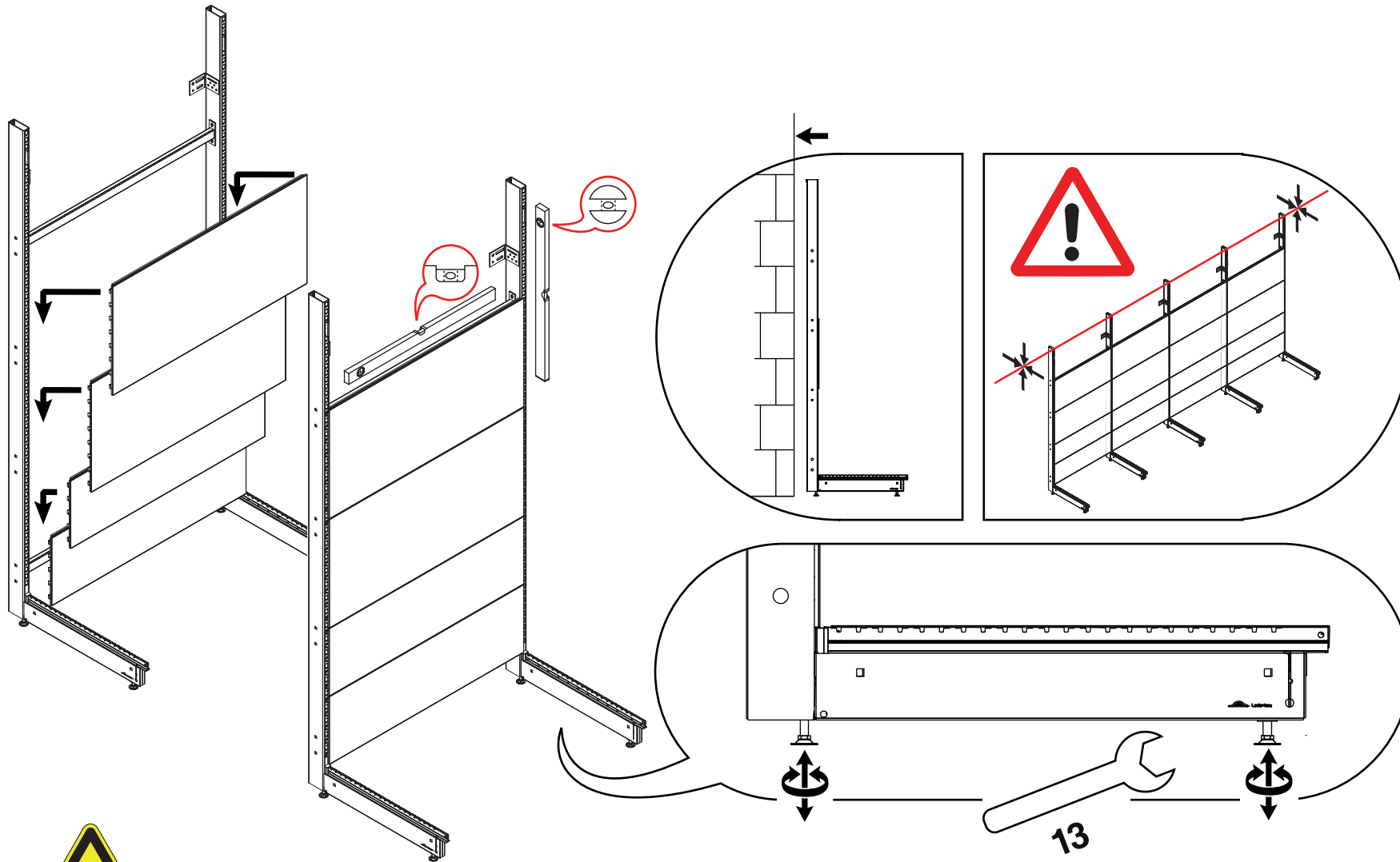
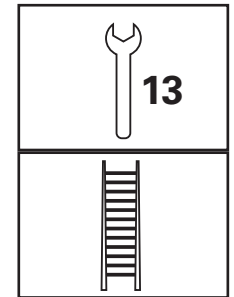

Werkzeuge / Tools

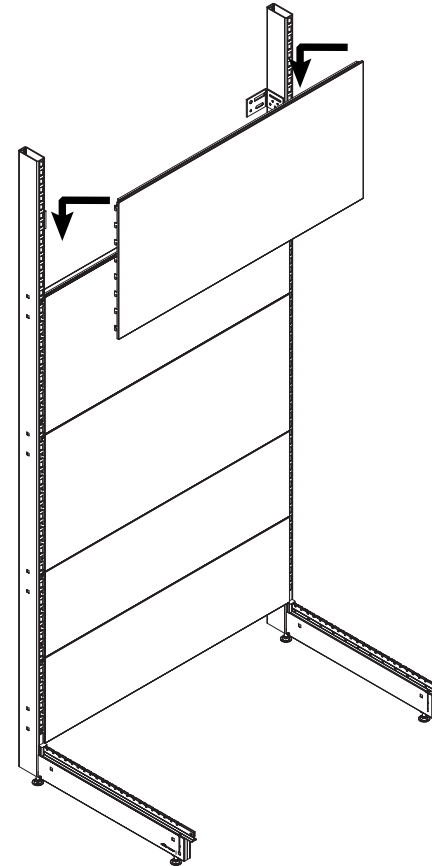
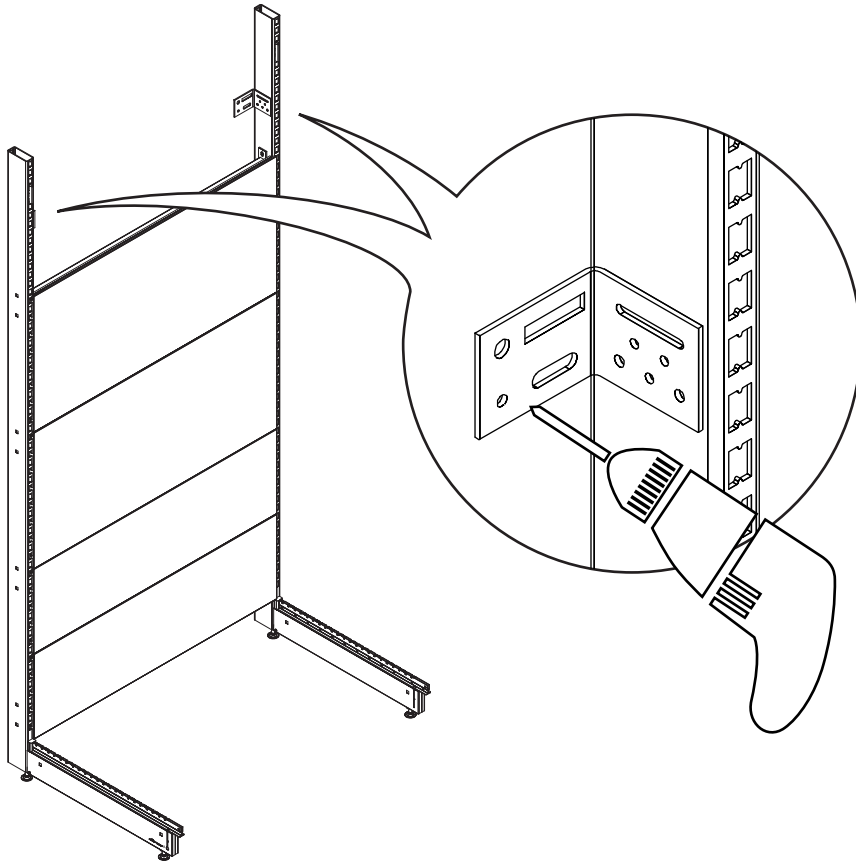
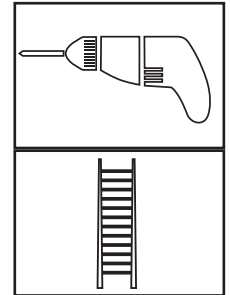

Optional einsetzbar
Optional additionally

Werkzeuge / Tools

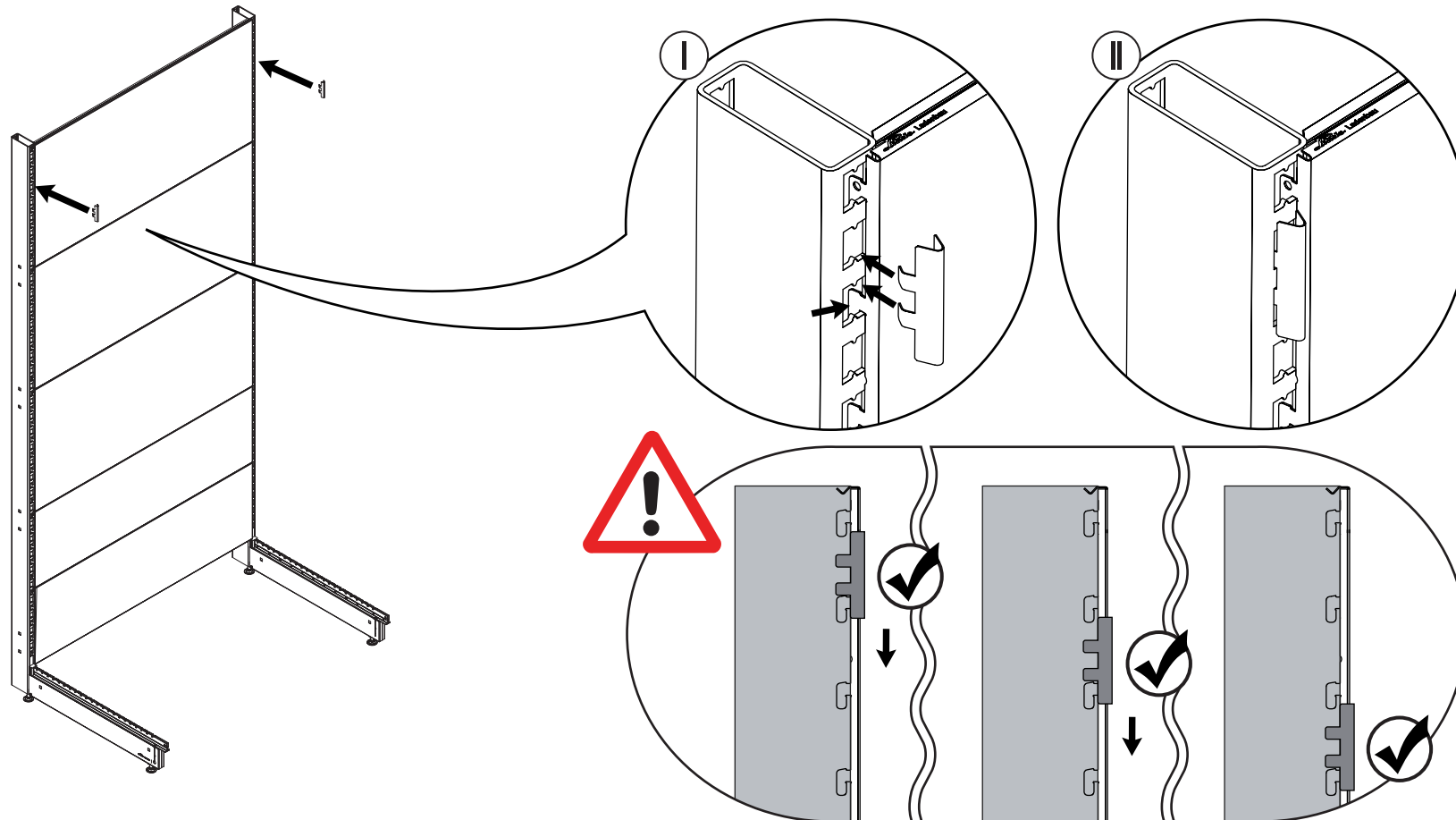
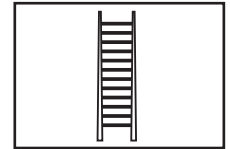

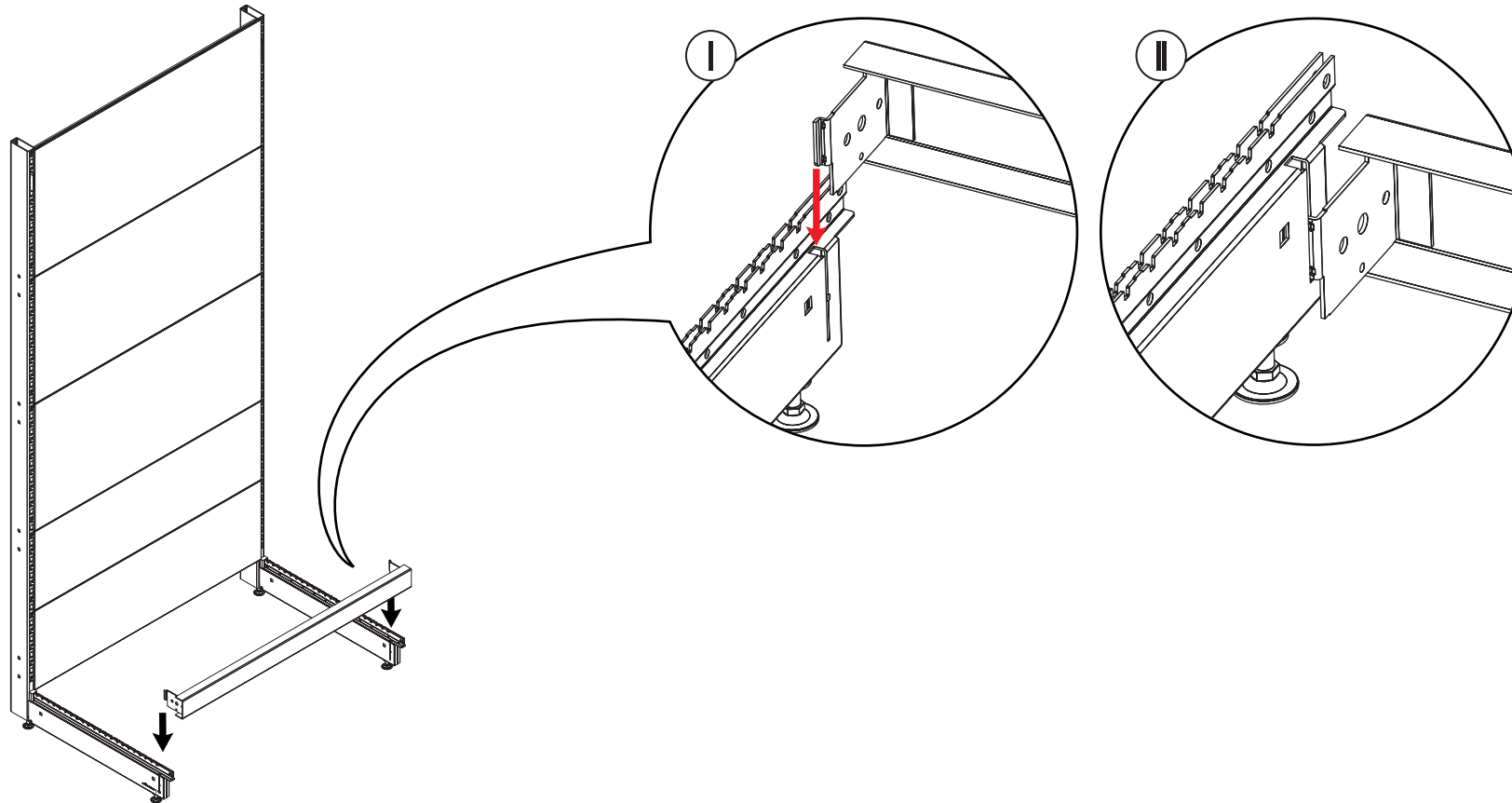

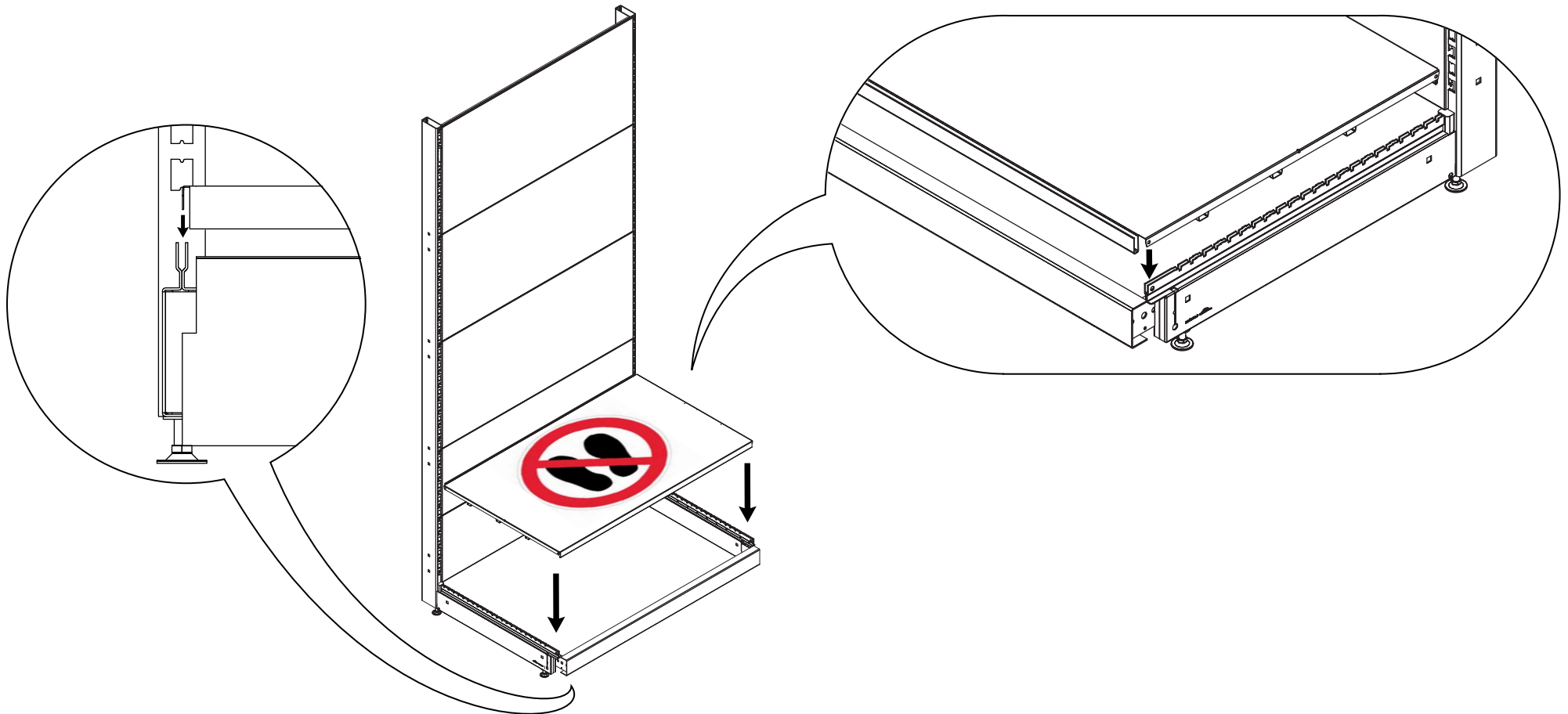

Optional einsetzbar
Optional additionally

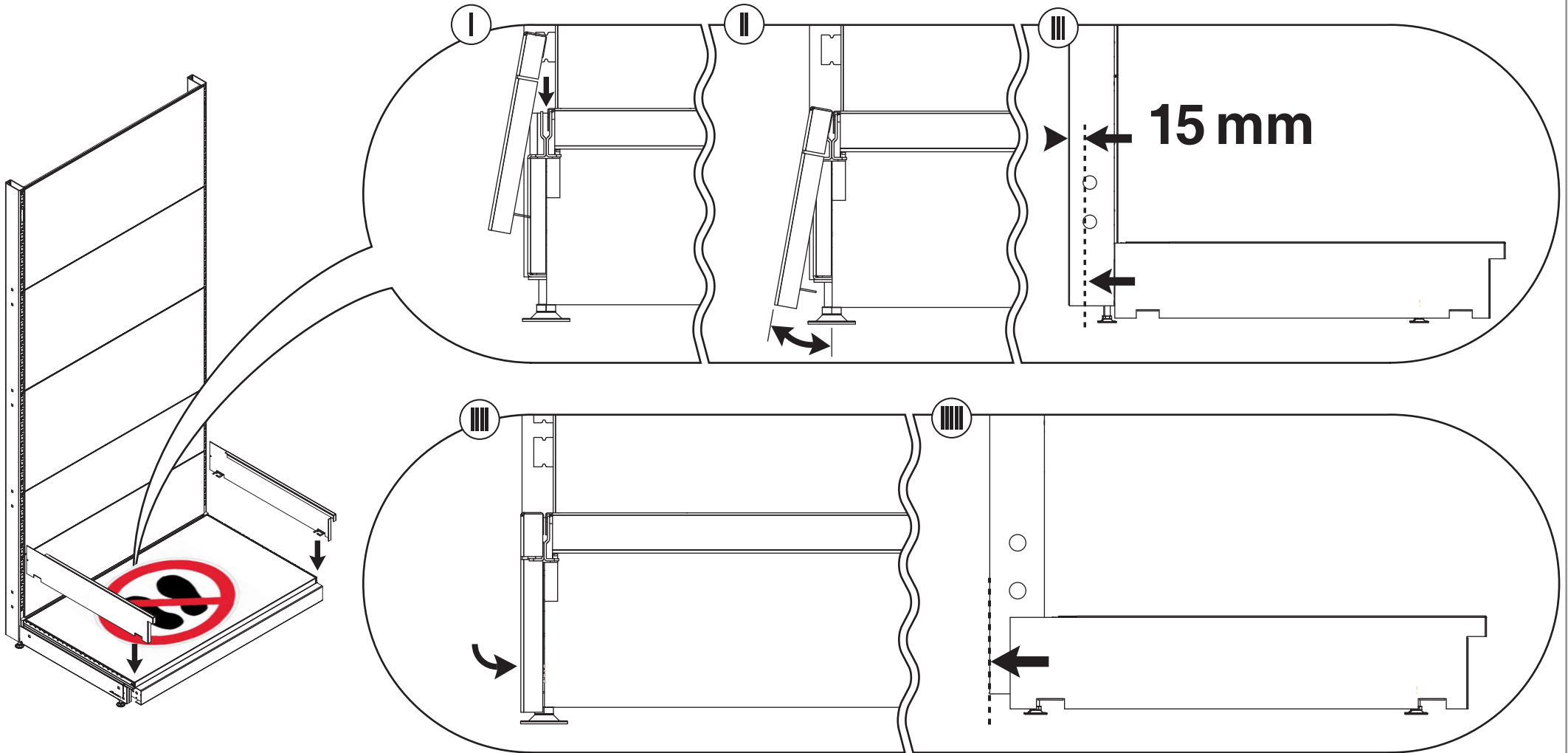

Konsolen und Böden nach Bedarf!
Brackets and shelves as required!

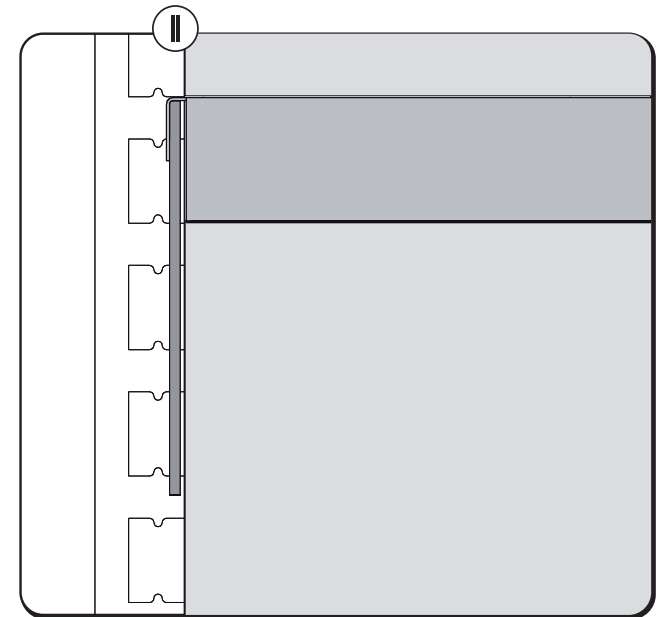
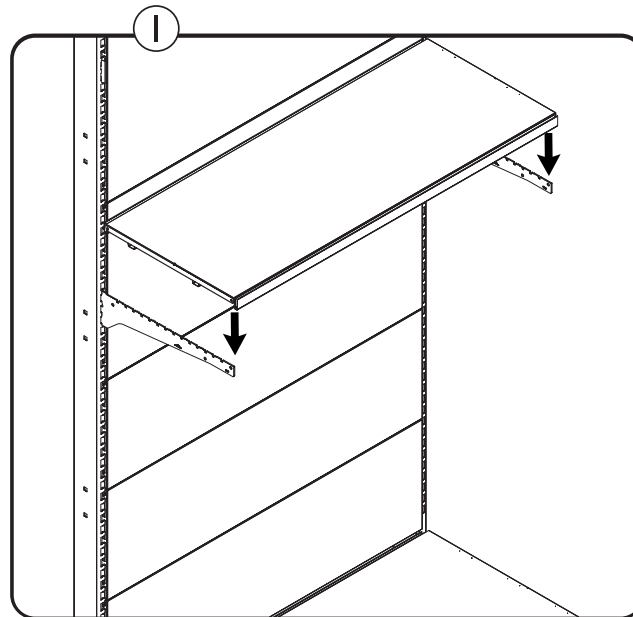
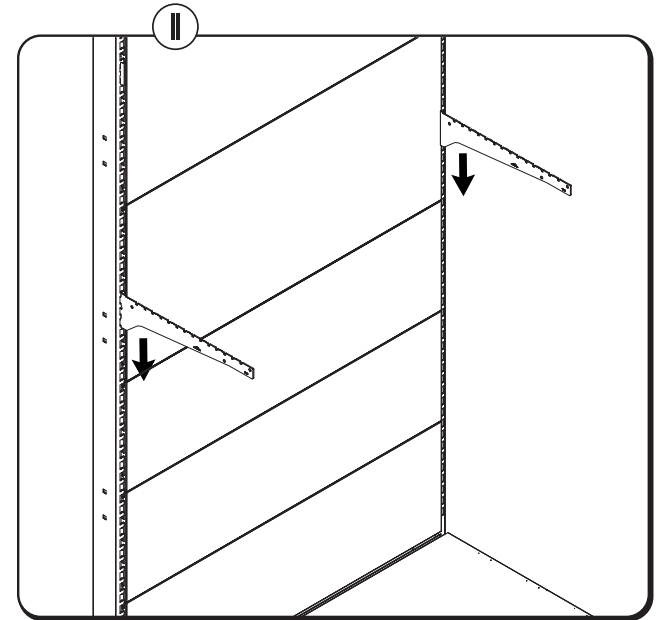
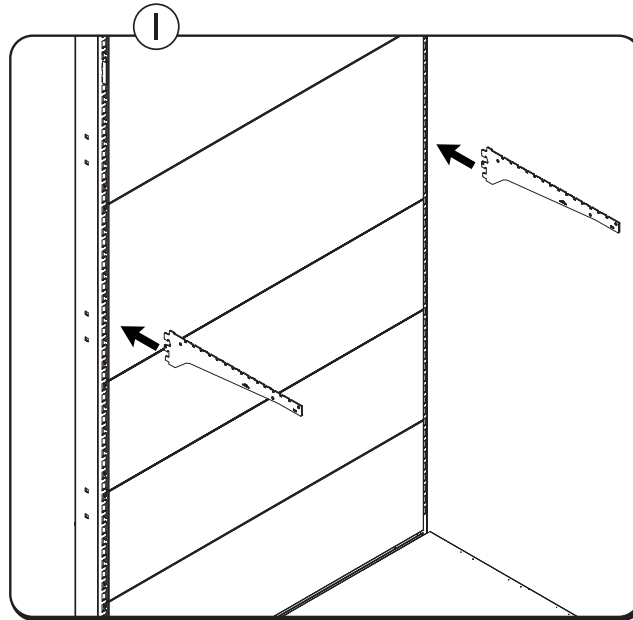
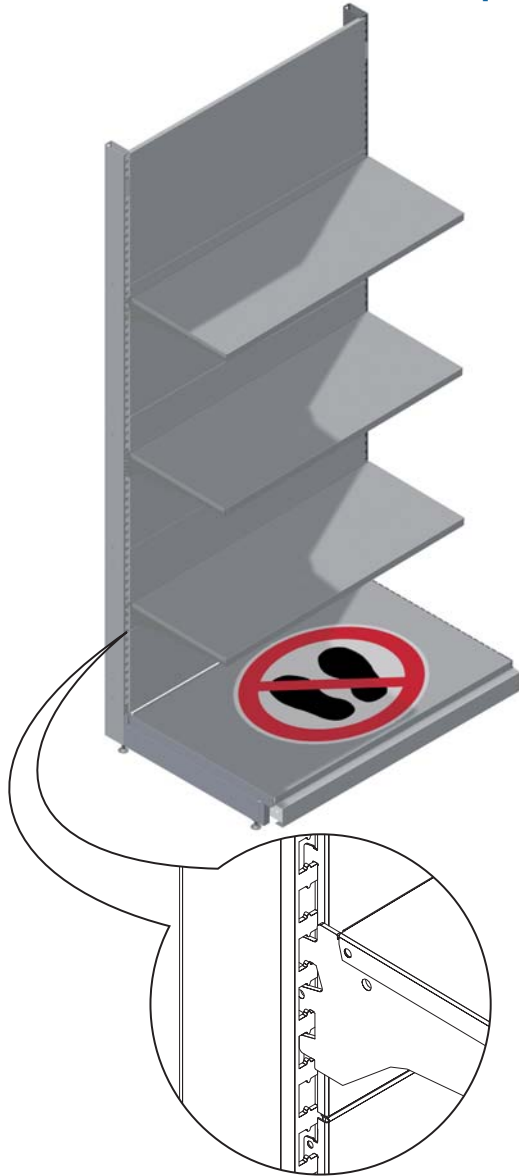



D Zur Pflege der Ladenbaueinrichtung ein leicht feuchtes Schwamm- oder Haushaltstuch mit mildem Spülmittel verwenden. Trocken nachwischen.

E For maintenance of the shopfitting parts please use a slightly-moistened sponge or cloth with mild detergents. Wipe dry afterwards.

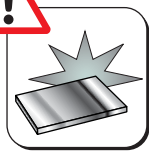

D Die Verwendung von Putztüchern muss getrennt für **Edelstahl** und sonstige Materialien erfolgen.

E Please use separate cleaning cloths for **stainless steel** and other materials.



D Edelstahl immer erst trocken vorreinigen, Schmutz, Staub, etc. entfernen.

Kein Kontakt der Edelstahlfächen mit anderen Metallen zulässig (Elektrokorrosion).



E Stainless steel has always to be wiped dry first, removal of dirt, dust, etc.

Contact between stainless steel surfaces and other metals is strictly prohibited (electro-corrosion).

D Alle lösemittelhaltigen Reinigungs-, Scheuer- und Poliermittel sind unzulässig!

E All solvent-based detergents, scrubbing or polishing agents are forbidden!

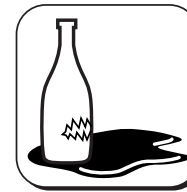

D Wasser sowie Flüssigkeiten aller Art schaden den Ladenbauteilen nachhaltig und lassen diese korrosiv reagieren.

Ausgelaufene Behältnisse und feuchte Stellen müssen immer umgehend getrocknet werden.

E Water as well as fluids of every description have a lasting and damaging effect on the shopfitting parts and leave them corrosive.

Leaking containers and moist spots have always to be dried up immediately.

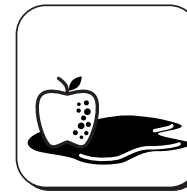

D Fruchtsäure greift die Oberfläche der Materialien besonders stark an.

Der gesamte O&G- Bereich ist regelmäßig zu reinigen.

E Fruit acid endamages the surface of the materials in particular.

The complete F&V area has to be cleaned regularly.

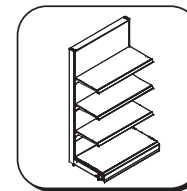

D Regalierung regelmäßig auf

- festen Stand
- beschädigte Teile, insbesondere Glasböden
- Verletzungsgefahren durch unsachgemäße Verbauung von Warenträgern
- Einhaltung der Belastungswerte

überprüfen und Mängel umgehend beseitigen!

E The shelf systems have to be checked regularly for

- secure stand
- damaged parts, especially glass shelves
- risks of injury by improper set-up of product carriers
- compliance with load capacities.

Any defects found have to be eliminated immediately!